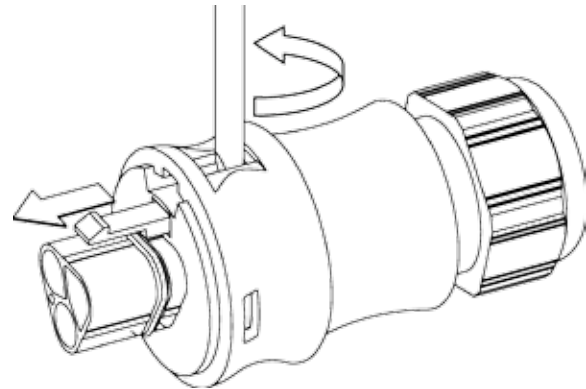
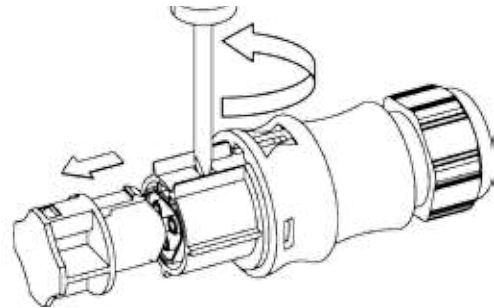

11. Replace Locking Clip

- A. Unscrew and move protective collars (If installed)
- B. Align a slotted screwdriver on the edge of the locking clip (Locking clip edge on connector housing)
- C. Push down and turn screwdriver 90 degrees
- D. Pull locking clip out
- E. Install new locking clip by pushing firmly into opening until locking clip "clicks" into housing

12. Remove Disconnect Caps

- A. Align a slotted screwdriver on the edge of the locking clip
- B. Push down and turn screwdriver 90 degrees
- C. Pull disconnect cap firmly off connector
- D. Ensure locking clip is installed in male insert or male disconnect cap

NOTE

In low temperate application the disconnect cap will maintain a very tight seal with high tensile resistance. Do not pry cap off with screwdriver.

Replacement Parts

Part #	Description
99.543.0000.7	Cover for 2&3 pole female connector inc. tether
99.545.0000.7	Cover for 2&3 pole male connector inc. tether
99.547.0000.7	Cover for 4&5 pole female connector inc. tether
99.549.0000.7	Cover for 4&5 pole male connector inc. tether
34.225.0062.8	Pozi-drive Screwdriver, 54mm length
34.225.0060.8	Pozi-drive Screwdriver, 80mm length
34.225.0061.8	Pozi-drive Screwdriver, 200mm length
05.583.2953.2	Locking Clip for Male Inserts, WHITE
06.502.4000.0	Flat (Slot) Screwdriver 0.6 x 3.5
06.502.4100.0	Flat (Slot) Screwdriver 0.8 x 4.0 x 100
06.502.4300.0	Flat (Slot) Screwdriver 0.4 x 2.5

Technical Data
Electrical

Rated Voltage:	600V
Rated Current:	20 / 30A
Wire Gauge:	20-12AWG (20A) 10AWG (30A)

Material

Contact Parts:	Brass, Special Plated for Oil and Gas applications (resistance to H ₂ S gas)
Housing Parts:	Thermoplastic material PA66, Halogen free, UL94-V2, UV stabilized
Collars:	Thermoplastic material PA66, Halogen free, UL94-V2, UV stabilized
Adapters:	Thermoplastic polymer material PC UL94-V2 Stabilized, UV Stabilized
Gaskets & Seals:	NBR

Mechanical

Number of Poles:	2,3,4 or 5
Housing Colour:	Black
Collar Colour:	Black
Insert Colour:	Various colours available, see product brochure for details
Ambient Temperature:	-40°C to +100°C
Mating Cycles:	100 cycles without load
Degree of Protection:	IP65, IP66, IP 67 & IP68; Type 6P (Canada); IK07
Coding:	Different colours* mechanically coded and will not intermate *Gray and Black of same pole count will intermate.

Approvals

Certifications (Ordinary Location):
 VDE; UL; CSA; LR; GL; DNV
 Certifications (Hazardous Location):
 cQPS File#LR1063
 Ex nA IIB+H2 T4 X (20A)
 Ex nA IIB+H2 T5 X (30A)
 Suitable for Class I, Zone 2 (Division 2) installations

Cable Specifications

20A, 600V, 20-12AWG:
 HL rated (extra hard usage) Industrial Tray Cable

30A, 600V, 10AWG:
 HL rated (extra hard usage) Industrial Tray Cable: 90°C rated or above

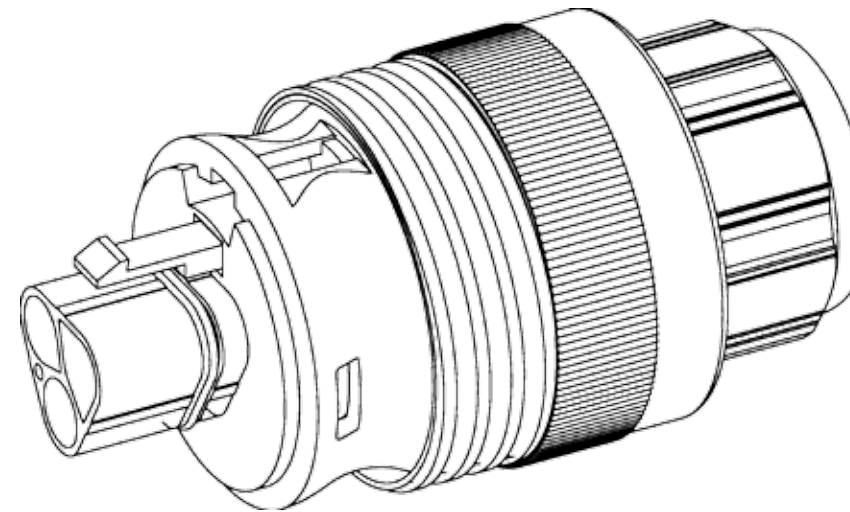
gesis RST 20i HD Z2
Installation and Assembly Instructions

Type gesis RST 20i2 HD Z2 (20A, 600V, 20-12AWG)
 Type gesis RST 20i3 HD Z2 (20A, 600V, 20-12AWG)
 Type gesis RST 20i4 HD Z2 (20A, 600V, 20-12AWG)
 Type gesis RST 20i5 HD Z2 (20A, 600V, 20-12AWG)

Type gesis RST 20i3 HD Z2 (30A, 600V, 10AWG)

34.205.0160.1 01/12

ENG Installation and Assembly Instructions

Type gesis RST 20i2 HD Z2 (20A, 600V, 20-12AWG)
Type gesis RST 20i3 HD Z2 (20A, 600V, 20-12AWG)
Type gesis RST 20i4 HD Z2 (20A, 600V, 20-12AWG)
Type gesis RST 20i5 HD Z2 (20A, 600V, 20-12AWG)

Type gesis RST 20i3 HD Z2 (30A, 600V, 10AWG)

1. Wire Preparation (For RST Insert)

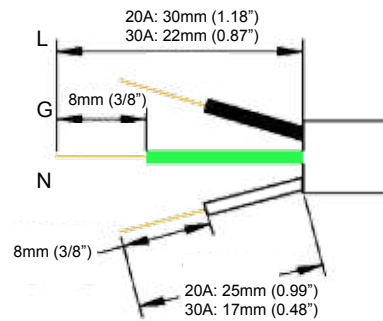

NOTE
The minimum bending radius for conductors larger than 14AWG is 4xOD of cable, or according to the specification listed by the cable manufacturer. Pull forces on the contact points can be avoided by ensuring the acceptable installation practice are followed as recommended by your local regulation body. Secure excess cable in the cable tray or protected location to minimize strain on connectors.

2. Wire Termination

- A. Feed cable through collar and connector housing.
- B. Terminate wires to screw terminals
- Ex. 3 Pole 120V connector:
L - Line (black)
N - Neutral (white)
G - Ground (green)

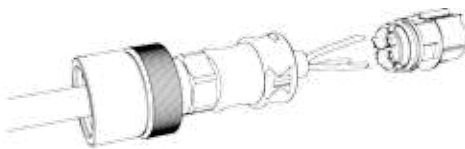

NOTE
POZIDRIV Screw Connection Torque (Typical): 1.0 Nm
Male protective collar installs on male connector.
Female protective collar installs on female connector

3. Install Insert

- A. Align slots on housing with tabs on insert
- B. Push insert into housing until both tabs "click" in place
- C. Tighten cable gland
- D. Ensure locking tab is installed in male insert

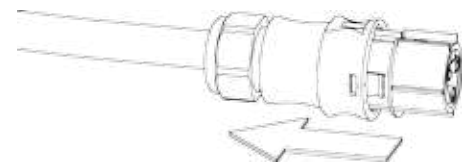

NOTE
Cable gland Torque (Typical): 5 Nm
Wieland recommends the use of Loctite™ Hysol® 425 on the threads of the cable gland nut during installation. (Do not use the Loctite™ on the thread of the protective collars.)

4. Connect Connectors

- A. Align locking clip and locking slot
- B. Push connectors firmly together until locking clip "clicks"
- C. Screw protective collars together

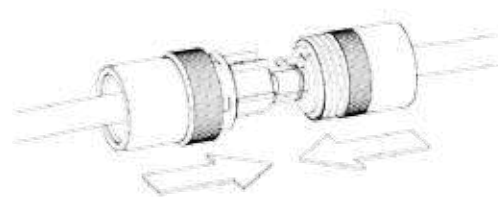

NOTE
Protective collars Torque (Typical): 5 Nm

5. Disconnect Connectors

- A. Unscrew protective collars
- B. Align a slotted screwdriver on the edge of the locking clip (Locking clip side that is centered between mated connectors)
- C. Push down and turn screwdriver 90 degrees
- D. Pull connectors firmly apart
- E. Ensure locking clip is installed in male insert

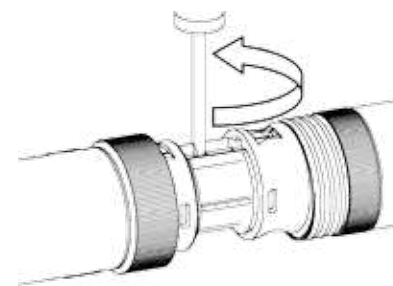

NOTE
Do not twist connectors to disconnect

6. Uninstall Insert

- A. Loosen cable gland
- B. Align slotted screwdriver on edge of the insert locking tab
- C. Push locking tab inward while pulling insert out
- D. Maintain outward pressure on insert
- E. Repeat for opposite insert locking tab

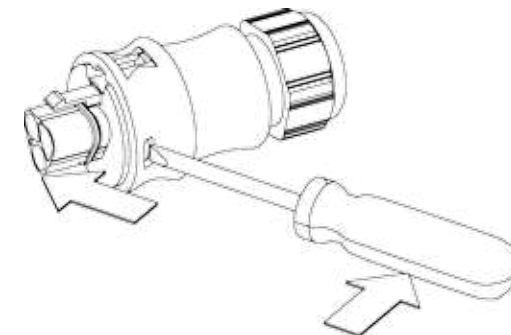

WARNING



- The connectors are not for current interrupting. Never connect or disconnect under load!
- Explosion hazard: Do not connect or disconnect while energized!
- Do not operate with damaged parts! Refer to parts lists on the back page for the list of replacement components.

IMPORTANT

Do not exceed the electrical ratings of the connector: RST 20i2, RST 20i3, RST 20i4, RST 20i5: 600V / 20 A / 20-12 AWG
RST 20i3: 600V / 30 A / 10 AWG

7. Install Panel Mount Housing

- A. Insert panel mount housing through collar
- B. Insert housing and collar through panel cut-out
- C. Screw on nut and torque
- D. Feed wires through housing
- E. Terminate device wires (see #2)
- F. Install insert (see #3)

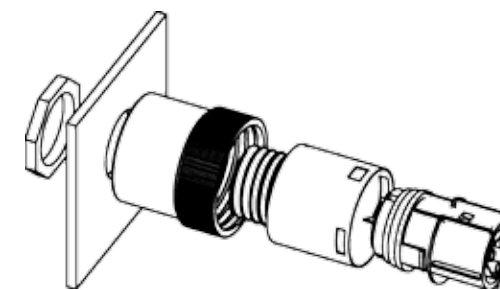

NOTE
Ensure the housing is oriented so that the locking clip on the insert is accessible for the screwdriver required to disconnect the mated inserts once all the panel mounted connectors are installed.

8. Uninstall Panel Mount Housing

- A. Loosen locking nut
- B. Remove housing from panel cut-out
- C. Remove collar from housing
- D. Uninstall insert (See #6)
- E. De-terminate wires

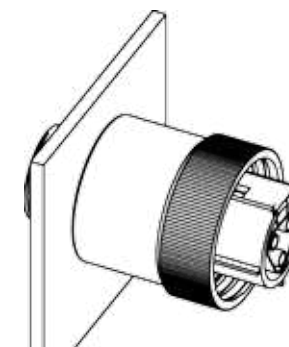

NOTE
Locknut Torque (Typical): 2.5 Nm
Wieland recommends the use of Loctite™ Hysol® 425 on the male threads of the M20 and M25 housing prior to screwing on the lock nut. (Do not use the Loctite™ on the thread of the protective collars.)

9. Install Device Mount Housing

- A. Insert device mount housing through collar
- B. Screw housing into the device NPT thread
- C. Tighten housing to the recommended torque.
- D. Feed device wiring through housing.
- E. Terminate device wires (see #2)
- F. Install insert (see #3)

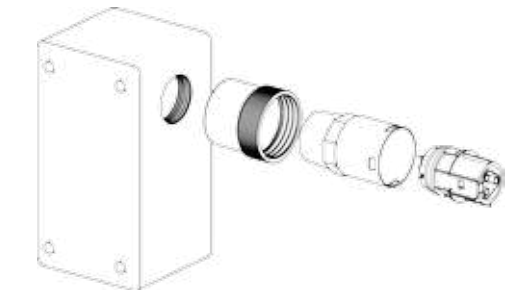

NOTE
Ensure the housing is oriented so that the locking clip on the insert is accessible for the screwdriver required to disconnect the mated inserts once the device is installed.

10. Uninstall Device Mount Housing

- A. Uninstall insert (See #6)
- B. De-Terminate wires
- C. Loosen housing from device NPT thread
- D. Remove collar from housing

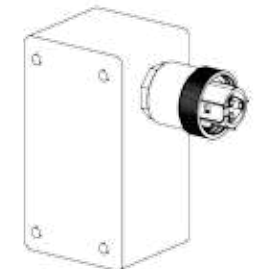

NOTE
NPT Housing Torque (Typical): 2.5 Nm
Wieland recommends the use of Loctite™ Hysol® 425 on the male threads on the 1/2"NPT or 3/4"NPT housing prior to screwing the housing into the device. (Do not use the Loctite™ Hysol® 425 on the threads of the protective collars.)

NOTE

Protection against accidental shock is generally ensured even when disconnected. Ground pin is first-make/last-break. Connection to the power feed cable must be with a female connector according to the local codes and accepted practices. Contacts in the cable connectors are protected against strain on the cable. For use in Class I, Zone 2 areas, the use of the mating collars and locking tab is required to satisfy the QPS (LR1063) approval. Connector sets installed in Class I, Zone 2 areas must not be disconnected under load.